



MODEL 5405

Face-Mounted Fountain



This fountain is certified to NSF/ANSI 61.



GENERAL

Face-mounted, one-piece fountain made of durable, non-corrosive, molded white composite material. Contour-formed basin with softly rounded corners and edges reduces splatter, insures proper drainage and prevents standing waste water.

BUBBLER

Single-stream angle jet bubbler. Combination self-closing push-button type, with integral automatic stream regulator and hood guard.

AUTOMATIC STREAM HEIGHT REGULATOR

Self-closing assembly is located inside unit to prevent tampering. Unit resists corrosion and liming. A constant stream height is automatically maintained under line pressures that vary from 20 to 105 psi.

INLET STRAINER

Easily cleaned in-line strainer screen traps particles of 140 microns or larger before they enter the waterway.

WATER INLET

3/8" O.D. Tubing

DRAIN OUTLET

1-1/4" tube outlet for 1-1/4" slip joint connection.

SUGGESTED SPECIFICATIONS

Fountain shall include pushbutton on the front, contour-formed basin to eliminate splashing and standing water, and shall have rounded corners and edges. Projector shall be two-stream, mound-building type with integral hood guard and anti-squirt feature. The manufacturer shall certify the unit to meet the requirements of NSF/ANSI 61, and the Safe Drinking Water Act.

Note: Continued product improvement makes specifications subject to change without notice. See Halsey Taylor website for most current spec sheet.

Standard finish is White

Each 5405 consists of 1 carton of the following:
Fountain

Service stop not included.

Shipping weight: 50 lbs.

JOB NAME: _____

 ENGINEER/CONTRACTOR NAME:

 APPROVAL: _____
 DATE: _____



5405

Composite Face-Mounted Fountain

(CONTINUED)

MOUNTING INSTRUCTIONS

Refer to diagrams for rough-in of plumbing.
For wall support required locations see installation instructions provided with fountain. Water service line and waste line are to be assembled as required. Final check for leaks and correct functions of fountain should be made. (For details see the installation instructions.)

NOTE: A service supply stop (not included) should be installed at the fountain inlet line.

CAUTION – Fountain must be securely bolted to wall.

OPERATING PRESSURES

Supply water-105 psi maximum

SIDE VIEW

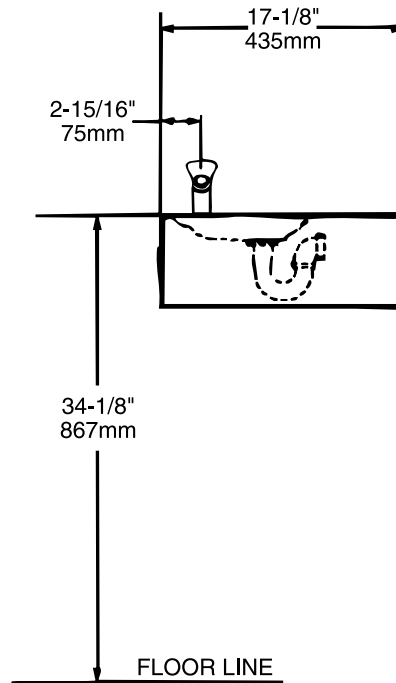

TOP VIEW

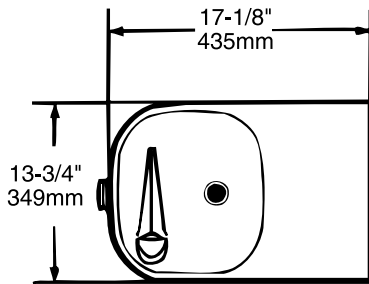

WALL LAYOUT

